

CONVERSIO

MASSE	P-500
Leuchtenkörper	∅ 500 x 50 mm (∅ x H)
Baldachin	∅ 160 x 40 mm (∅ x H)
Raumhöhe	bis maximal 2,7 Meter
Sonderversionen	für Räume ab 2,7 m Raumhöhe
Gewicht	1'900 g

AUSFÜHRUNG

Material Leuchtenkörper	Aluminium geschliffen, eloxiert
Material Mechanik	rostfreier Stahl
Farbe	farblos champagne (BWB-Colinal 3115) nougat (BWB-Colinal 3165) mocca (BWB-Colinal 3178)
Farbe Kabel	schwarz matt

ELEKTRISCHE DATEN

Spannung	100–240 V / 50–60 Hz
LED	336 Stück
Lebensdauer LED	30'000 h
Farbtemperatur	2'700 Kelvin (warmweiss)
Beleuchtungsstärke	600 Lux (600mm unter Leuchte gemessen)
Lichtstrom	2150 Lumen
Stromverbrauch	max. 25 Watt
Normen	▽ ⊕ CE Schutzklasse IP-40
Lichtlenkung	5–95%, stufenlos verstellbar
Ausführung dimmbar	mit gebäudeseitigem Dimmer 1–10V (getestet mit Berker 289110 und Feller 40600.1–10V)
Ausführung dimmbar Bluetooth	via CASAMBI-App

illuminartis c/o
werk14 AG
Fabrikstrasse 14
CH-3455 Grünen
T +41 34 432 41 44
www.illuminartis.ch
info@illuminartis.ch



illuminartis

DIE LICHT MANUFAKTUR

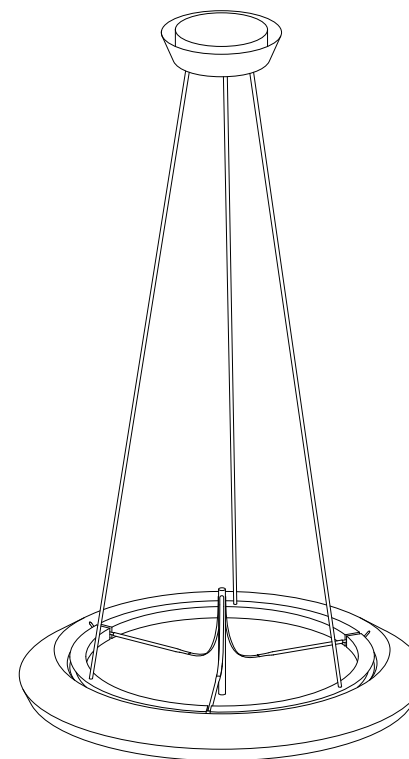

CONVERSIO swissmade

MONTAGE- UND BEDIENUNGSANLEITUNG

INSTALLATION AND OPERATING INSTRUCTIONS

MONTAGE ET MODE D'EMPLOI

ISTRUZIONI D'USO E DI MONTAGGIO

MONTAGEANLEITUNG

INSTALLATION INSTRUCTIONS

MODE DE MONTAGE

ISTRUZIONI DI MONTAGGIO

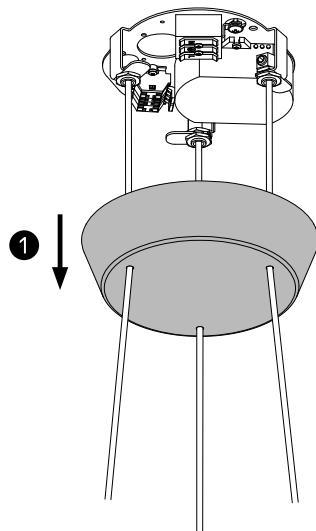
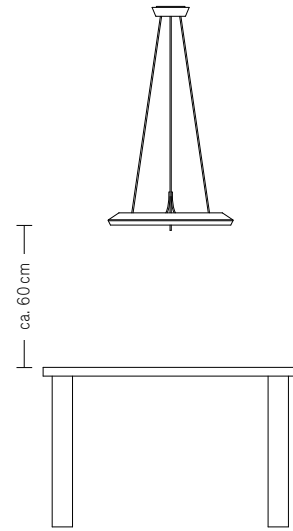
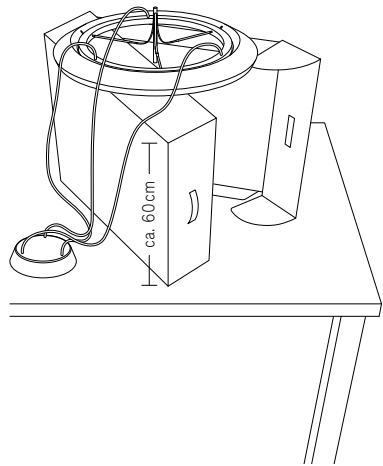

ISTRUZIONI D'USO

ITALIANO

MANUTENZIONE

MONTAGGIO E COLLEGAMENTO

Il montaggio della lampada e il collegamento alla rete elettrica devono essere eseguiti esclusivamente da un elettricista autorizzato.

ACCENSIONE E SPEGNIMENTO DELLA LUCE

La luce viene accesa e spenta con l'interruttore a lato dell'immobile. Non è possibile effettuare un collegamento con un dimmer a lato dell'immobile!

ORIENTAMENTO DELLA LUCE

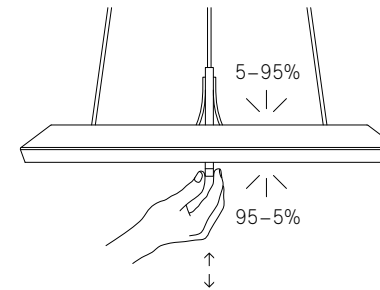

Posizione	Flusso di luce inferiore	Flusso di luce superiore
superiore	5%	95%
centrale	75%	25%
inferiore	95%	5%

FUSIBILE DI SICUREZZA

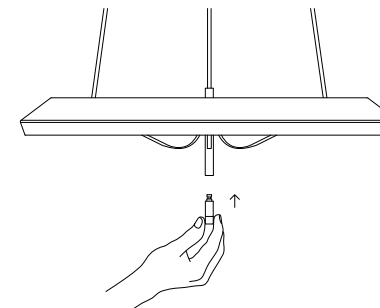

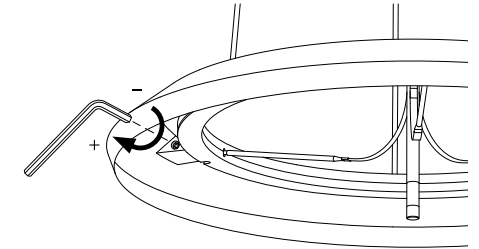

REGISTRAZIONE DEL BILANCIAMENTO

Occorre effettuare la registrazione in tutti e 3 i punti di regolazione se, in caso di cambiamento dell'orientamento della luce, la posizione (bilanciamento) non si mantiene autonomamente.



DATI TECNICI / SIMBOLI

 Interrompere sempre l'alimentazione durante il montaggio, la regolazione e gli interventi di manutenzione.

 100-240 V / 50-60 Hz

 Lampadina 336 LED / bianco calda / totale 25 Watt / 600 Lux / durata ca. 30.000 h

 Dimmerabili

 Non dimmerabili

 La lampada deve essere pulita con un panno morbido imbevuto in una soluzione di acqua tiepida e di qualche goccia di detergente delicato (ad es. detersivo per i piatti) e ben strizzato. Il liquido non deve per nessun motivo penetrare fra il corpo della lampada in alluminio e il diffusore in plastica raggiungendo in questo modo i componenti elettronici.

 La lampada non può essere montata e utilizzata all'aperto (protezione IP40)

 Classe di protezione 1

 La lampada può essere fissata su superfici normalmente infiammabili.

 Per lo smaltimento la lampada deve essere conferita a un centro di smaltimento o al punto di acquisto.



MONTAGE ET BRANCHEMENT

Le montage ainsi que le branchement au courant en bonne et due forme de la lampe ne pourront être effectués que par un électricien possédant une concession !

ALLUMER/ÉTEINDRE LE LUMINAIRE

Le luminaire est allumé et éteint au moyen de l'interrupteur situé dans le bâtiment. Le raccordement à un variateur existant dans le bâtiment n'est pas possible!

ÉLÉMENT DE GUIDAGE DE LA LUMIÈRE

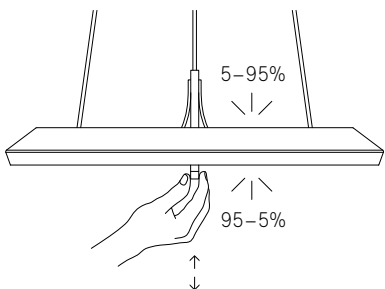

Position	Pourcentage de lumière en bas	Pourcentage de lumière en haut
En haut	5%	95%
Au milieu	75%	25%
En bas	95%	5%

SÉCURITÉ ANTI-SURCHARGE

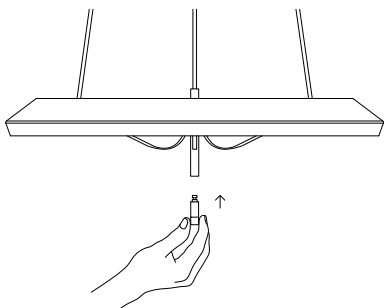





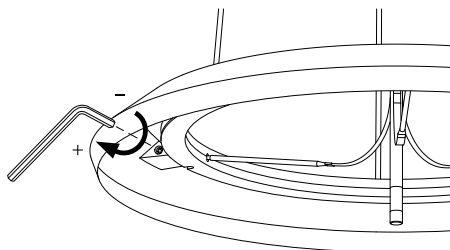





RÉGLAGE DE L'ÉQUILIBRE

Le réglage doit être fait sur les 3 points prévus à cet effet si la position (l'équilibre) n'est plus maintenue de manière autonome en cas de changement intervenant au niveau du guidage de la lumière.



DONNEES TECHNIQUES / SYMBOLES

-  Toujours interrompre l'alimentation en courant pendant montage, installation et opérations de maintenance.
-  100-240 V / 50-60 Hz
-  Ampoule 336 LED / blanc chaud / total 25 watts / 600 lux / durée de vie env. 30'000 h
-  Dimmable
-  Pas dimmable
-  Le luminaire doit être nettoyé avec un chiffon doux imbibé d'une solution d'eau tiède et de quelques gouttes de produit de nettoyage doux (p. ex. produit vaisselle) et bien essoré. En aucun cas le liquide ne devra pénétrer dans l'électronique se situant entre la lampe en aluminium et le diffuseur en plastique.

-  Ne pas monter et/ou utiliser la lampe à l'air libre (protection IP40).
-  Classe de protection 1
-  La lampe pourra être montée sur toute surface normalement inflammable.
-  Pour la mise au rebut, rapporter la lampe à un centre de recyclage ou au point de vente.

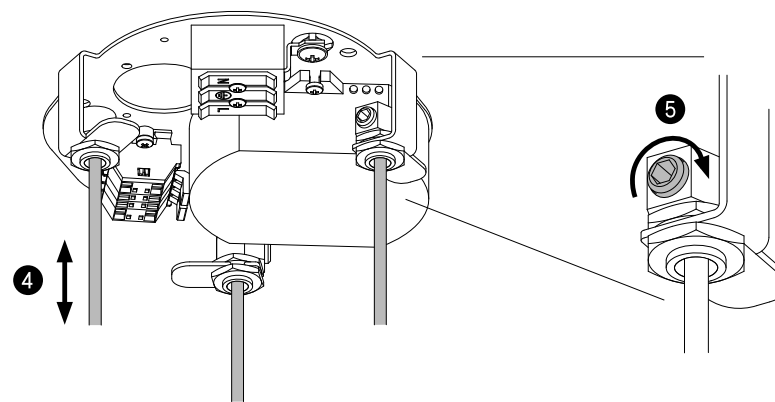
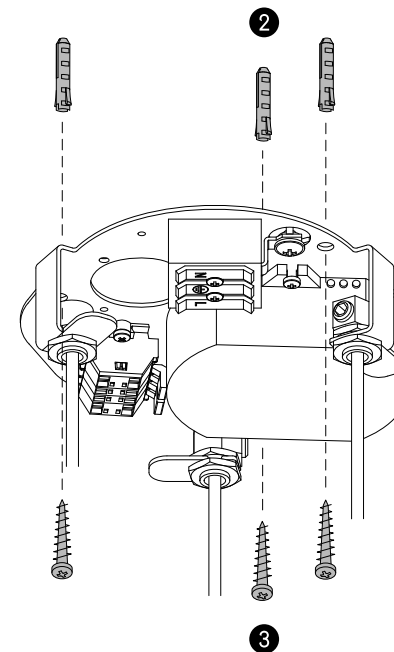



NICHT DIMMBAR
NON-DIMMABLE
PAS DIMMABLE
NON DIMMERABILI

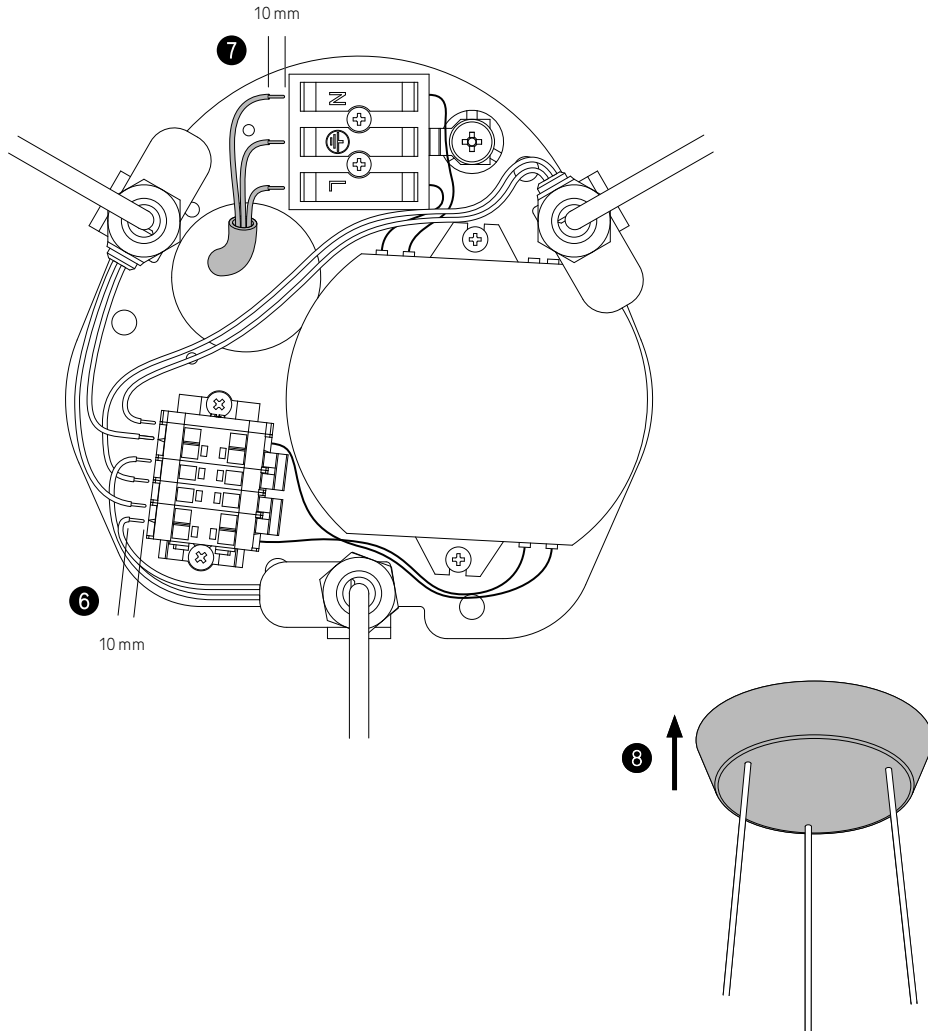

OPERATING INSTRUCTIONS ENGLISH

INSTALLATION AND CONNECTION

Professional installation of the lamp and connection to the power supply must only be carried out by a licensed electrician!

SWITCHING THE LAMP ON/OFF

The lamp is switched on/off via the switch in the building. It cannot be connected to a dimmer switch in the building!

DIRECTION OF THE LIGHT

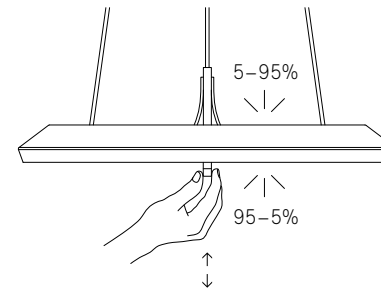

Position	Portion of floor illumination	Portion of ceiling illumination
Top	5%	95%
Centre	75%	25%
Bottom	95%	5%

OVERLOAD PROTECTION

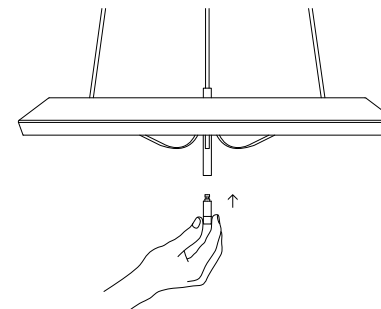







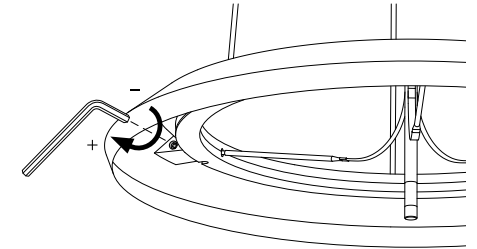



MAINTENANCE

BALANCE ADJUSTMENT

If, in the case that the direction of the light changes, the position (balance) is no longer maintained autonomously, then all 3 points of adjustment must be adjusted.



TECHNICAL SPECIFICATIONS/SYMBOLS

-  Always disconnect power supply for installation, setting and maintenance.
-  100-240 V / 50-60 Hz
-  Illuminant 336 LED / warm white / Total 25 Watt / 600 Lux / Lifespan approx. 30,000 h
-  Dimmable
-  Non-dimmable
-  The lamp should be cleaned with a soft cloth soaked in a solution of lukewarm water and a few drops of mild detergent (e.g. washing-up liquid) that has been well wrung out. Under no circumstances must liquid enter the electronic circuit between the aluminium lamp body and the plastic diffuser.
-  The lamp must not be installed and used outdoors (IP40 protection rating)
-  Protection rating 1
-  The lamp can be mounted onto normally inflammable surfaces.
-  When disposing of the lamp, it is to be returned to a disposal centre or the sales outlet.



MONTAGE UND ANSCHLUSS

Die fachgerechte Montage der Leuchte und der Anschluss der Stromzufuhr dürfen nur durch einen konzessionierten Elektriker vorgenommen werden!

EIN-/AUSSCHALTEN DER LEUCHTE

Die Leuchte wird über den gebäudeseitigen Schalter ein- und ausgeschaltet. Ein Anschluss an einen gebäudeseitigen Dimmer ist nur bei der Ausführung mit dimmbarem Netzteil /1-10V möglich.

LICHTLENKUNG

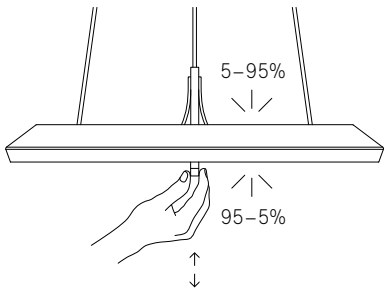

Position	Lichtanteil unten	Lichtanteil oben
oben	5%	95%
mitte	75%	25%
unten	95%	5%

ÜBERLASTSICHERUNG

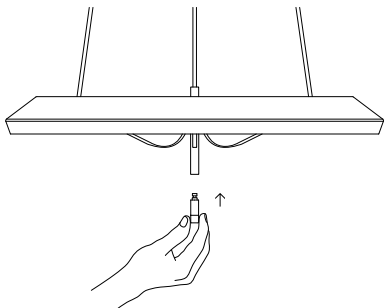





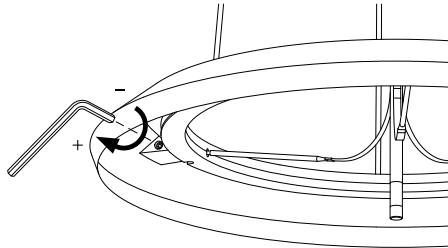





JUSTIERUNG DER BALANCE

Die Justierung an allen 3 Verstellpunkten ist vorzunehmen, wenn bei einer Veränderung der Lichtlenkung die Position (Balance) nicht mehr selbständig gehalten wird.



TECHNISCHE ANGABEN / SYMBOLE

-  Bei Montage, Einstellung und Wartungsarbeiten immer Stromzufuhr unterbrechen.
-  100-240 V / 50-60 Hz
-  Leuchtmittel 336 LED / warmweiss / Total 25 Watt / 600 Lux / Lebensdauer ca. 30'000 h
-  Dimmbar
-  Nicht dimmbar
-  Die Leuchte ist mit einem in einer Lösung aus lauwarmem Wasser und ein paar Tropfen milden Reinigungsmittels (z.B. Abwaschmittel) getränktem und gut ausgewringenen weichen Tuch zu reinigen. Flüssigkeit darf unter keinen Umständen zwischen dem Aluminium-Leuchtenkörper und dem Kunststoff-Diffusor in die Elektronik eindringen.
-  Die Leuchte darf nicht im Freien montiert und verwendet werden (Schutzart IP40)
-  Schutzklasse 1
-  Die Leuchte kann auf normal entflammbaren Oberflächen befestigt werden.
-  Die Leuchte ist zur Entsorgung einer Entsorgungsstelle oder der Verkaufsstelle zurückzugeben.



DIMMBAR
DIMMABLE
DIMMABLE
DIMMERABILI

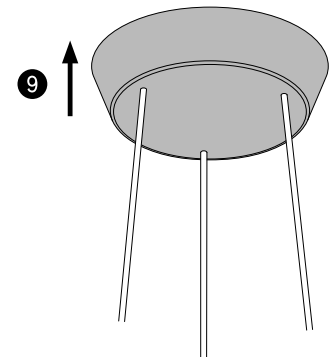
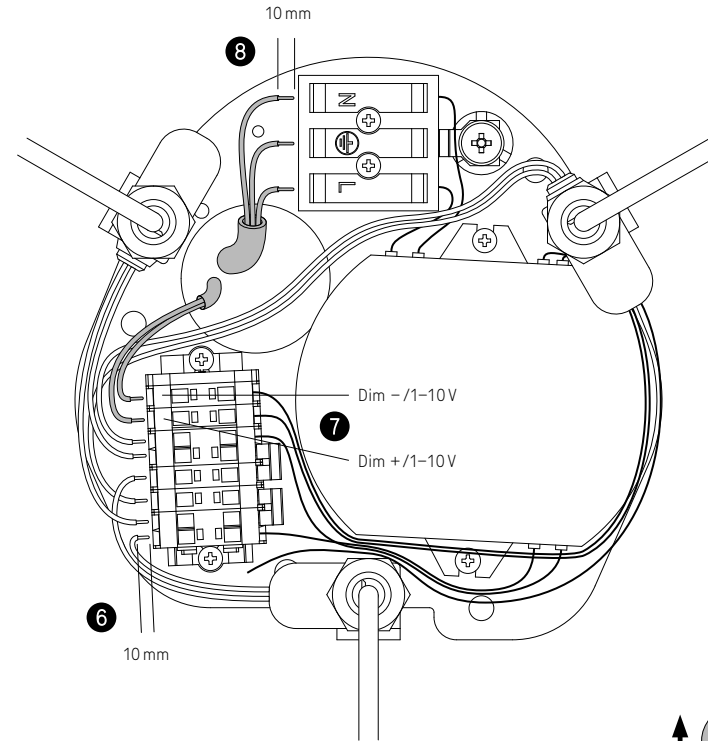

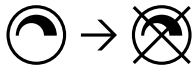

DIMMABLE ZU NICHT DIMMABLE UMSTELLEN
 SWITCH FROM DIMMABLE TO NON-DIMMABLE
 CHANGER DE DIMMABLE À PAS DIMMABLE
 PASSARE DA DIMMERABILI A NON DIMMERABILI

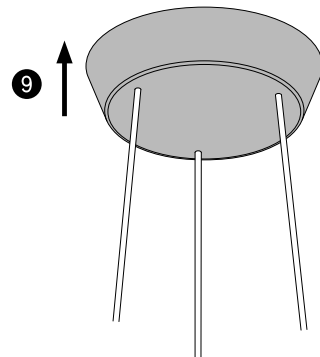
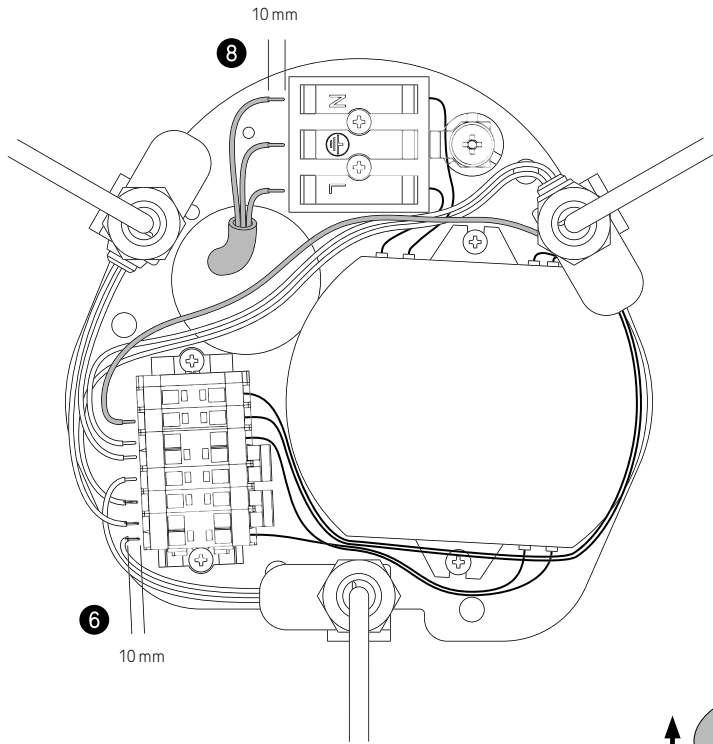

DIMMABLE MIT BLUETOOTH (VIA CASAMBI-APP)
 DIMMABLE WITH BLUETOOTH (VIA CASAMBI-APP)
 DIMMABLE AVEC BLUETOOTH (VIA CASAMBI-APP)
 DIMMERABILI CON BLUETOOTH (VIA CASAMBI-APP)

